

## Filter Handbook

In the following pages you will find the basic principles of filtration illustrated and explained using simple examples.

**For filtration and hydraulics specialists requiring more detailed information, we recommend downloading our complete filter handbook ([www.hydac.com](http://www.hydac.com)).**

If you have any questions about the contents of this brochure or if you have a specific problem to solve, we will be happy to help you in person. Please contact your nearest HYDAC representative or contact our headquarters.

### Awareness of fluids

As a manufacturer or operator of machines or systems in today's fast-moving and globalised market in Central Europe, we must make use of every possible means to continually improve competitiveness.

Primarily, this implies reduction in costs, not only of the purchase cost but of all costs generated during the **whole lifetime** of the system (Life Cycle Cost Reduction).

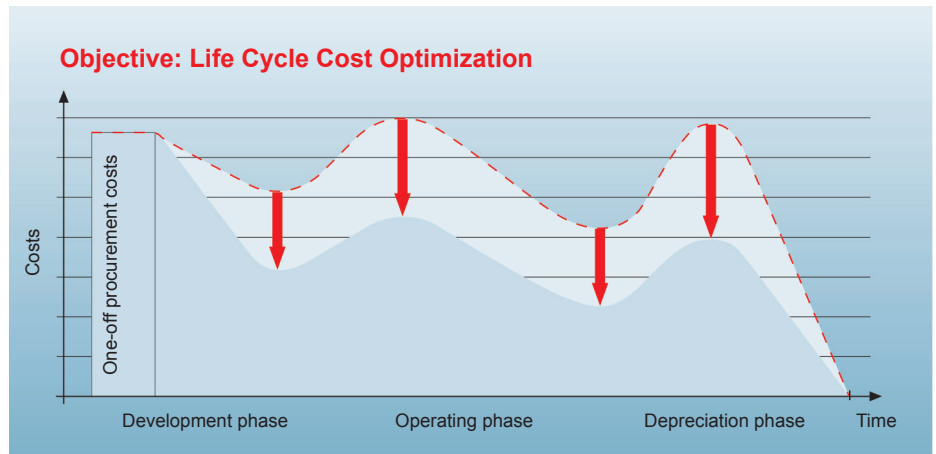

The condition of the operating fluid plays a key role in this objective since approximately **70 % of all breakdowns of hydraulic and lubrication systems can be attributed to the condition of the oil** – with proven detrimental effects on the efficiency and profitability of systems and equipment.

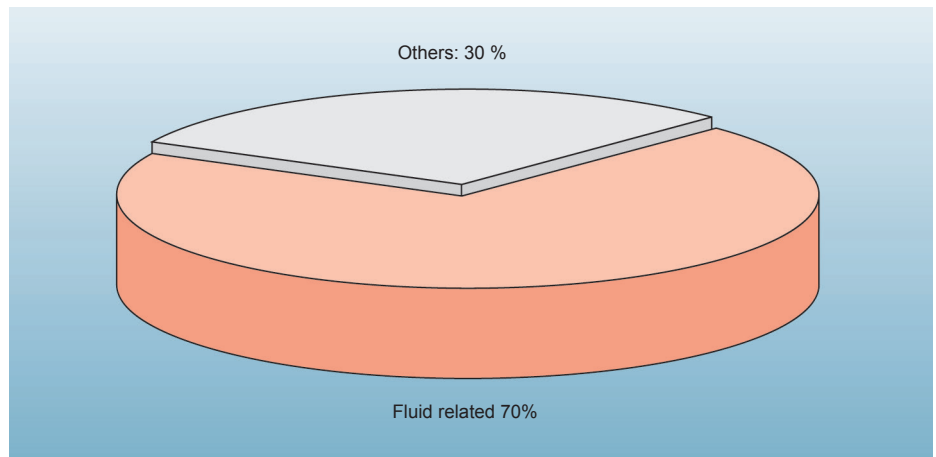

Causes of breakdowns in hydraulic and lubrication systems

Once the direct connection between fluid condition and the profitability of hydraulic and lubrication systems is recognised, the action required becomes obvious: cooling, continuous online monitoring and a well-engineered filtration concept, which guarantee the efficiency and operational reliability of the entire system.

Although this filtration handbook - as the name suggests - deals primarily with the "filter" component, HYDAC experts will also provide you with modern solutions which are specific to your system in the areas of cooling and condition monitoring.

Only by taking an integrated approach is it possible to improve the condition of the fluid used and to reduce the Life Cycle Costs.

As HYDAC's hydraulic experts, we want to focus attention on **fluid awareness** and we would like to share our experience with you. The following pages relate to filtration, but we can also help you in relation to cooling and condition monitoring if required.

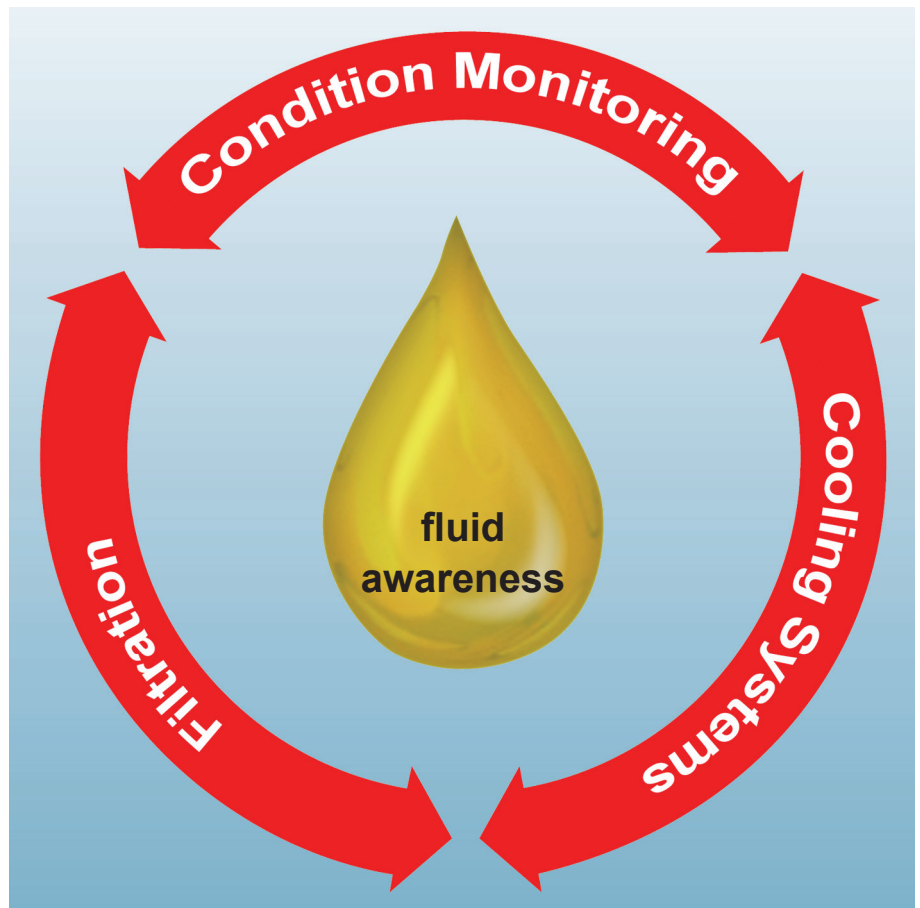

## Why is filtration so important?

Selecting the optimum filtration solution contributes significantly to preventing damage caused by contamination, to increasing the availability of the system and therefore to increasing productivity considerably.

The new filter element technology Betamicron®4 has been specially developed for the reduction of the Life Cycle Cost. The previous glass fibre elements from HYDAC (Betamicron®3 generation) provided complete security: a high level of fluid cleanliness and long-term stability for your hydraulic or lubrication system.

The new generation goes one better: with further improvements to the performance data the elements with Betamicron®4 technology ensure the highest fluid cleanliness. By optimizing the filter media structure both the separation performance and the contamination retention capacity have increased to a large extent. This means that sensitive components are protected over the long term and the filter element has a significantly longer service life.

Furthermore, even fluids with extremely low conductivity can be filtered without electrostatic discharge taking place within the filter element, due to a special feature of the filter mesh pack. This is another benefit therefore in the area of operating reliability and gives HYDAC the cutting edge in the area of element innovation.

The table on the right summarizes the positive effect of the new element technology, Betamicron®4, on the Life Cycle Cost of your machine or system.



		Optimised mesh-pack structure	Optimised longitudinal seam	Zinc-free composition	Spiral lock support tube	Protective outer sleeve	Electr. discharge capability
		minimises					
energy	costs	●					
Manpower		●	●			●	●
Logistics				●	●		
Failure		●	●	●		●	●
Production		●	●				●
Repair		●	●	●		●	●
Maintenance		●	●	●		●	●
Spare parts		●	●	●		●	●
Waste disposal					●		

More detailed information such as technical specifications and customer benefits can be found in the brochure "Filter Elements Betamicron®4. For Reduced Life Cycle Cost".

## What kinds of damage does contamination cause?

Contamination has a detrimental effect on the function of hydraulic and lubricating fluids, e.g. the transfer of heat and energy, even to the point of system failure.

Subsequent damage analyses have shown that approx. 75% of system failures are attributed to damage to the components used - caused by contamination in the operating fluid.

## Causes of contamination

What are the causes of contamination and which mechanisms can lead to a rise in the costs outlined above?

The following illustration indicates possible contamination sources:

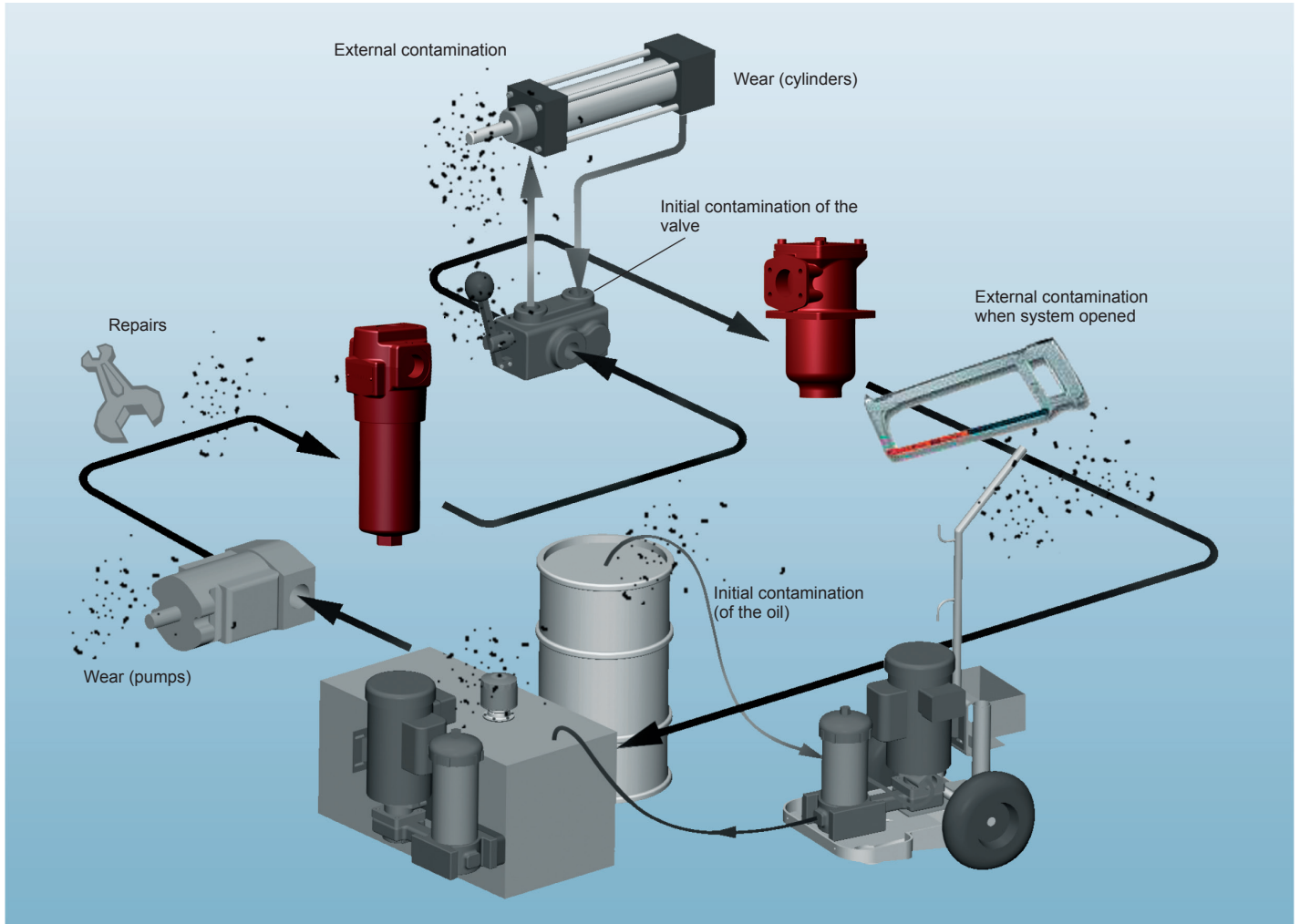

### Origin / formation of contamination:

Built-in contamination from integrated components (e.g. valves, fluids, cylinders, pumps, tanks, hydraulic motors, hoses, pipes)

Contamination produced during assembly of the system, by opening the system, during system operation and during fluid-related system failure.

Contamination entering from outside the system, through:

- tank breathing
- cylinders, seals

Contamination entering the system during maintenance procedures

- system assembly/disassembly
- opening the system
- filling with oil

If these, usually high-value components are damaged by solid contamination in the hydraulic and lubricating media, system faults, including unplanned shutdowns can occur.

The severity of the component damage depends on the material of the contamination, the operating pressure, the nature (round or sharp-edged) and size and quantity of particles.

As a rule of thumb: the harder the particles, the more extensive the component damage and the higher the operating pressure, the more forcefully the particles become lodged in the lubrication clearance.

It often goes unrecognized that the majority of these solid particles is smaller than 30  $\mu\text{m}$  and therefore they are not visible to the naked eye. This means an apparently clean fluid can, in fact, be badly contaminated.

Particularly critical are particles which are the same size as the clearance between moving parts.

This is compounded by the fact that hydraulic users are constantly demanding smaller and lighter, high-performance components, which reduces the clearance even further.

In the following diagrams you will find the typical clearances.

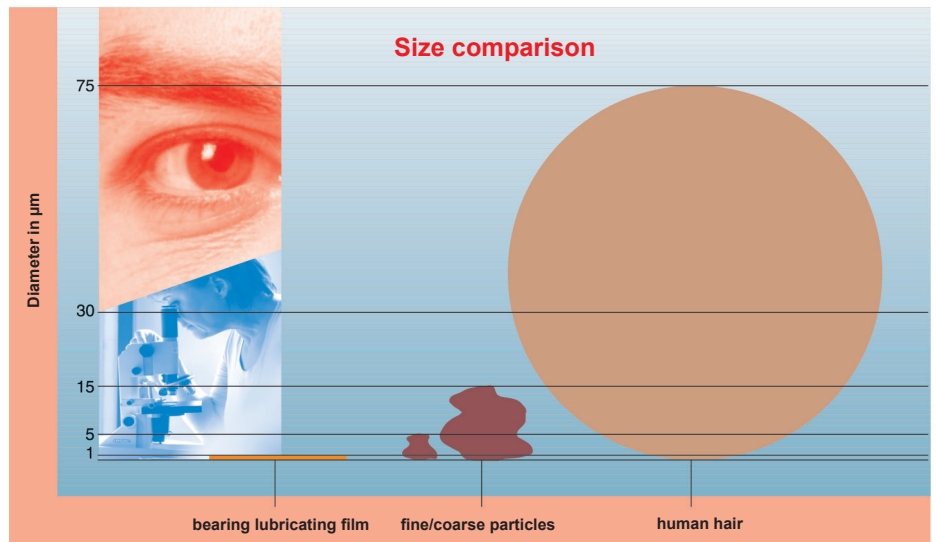

### On hydraulic pumps:

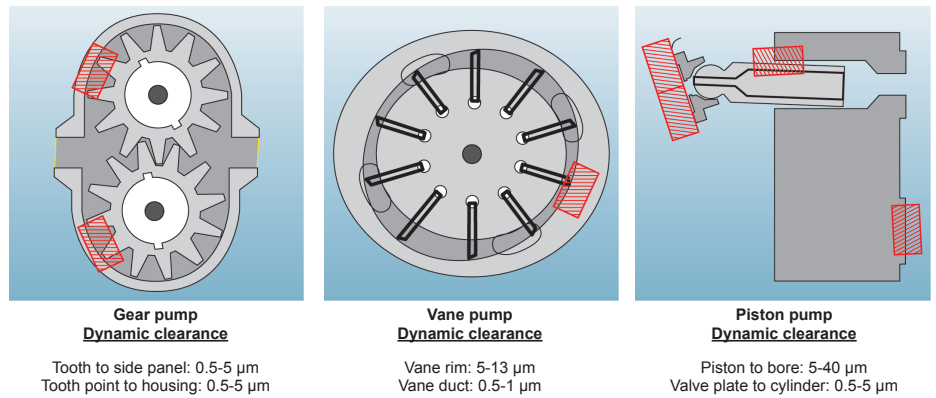

### On valves:

- Servo valve 1 - 4  $\mu\text{m}$
- Proportional valve 1 - 6  $\mu\text{m}$
- Directional control valve 2 - 8  $\mu\text{m}$

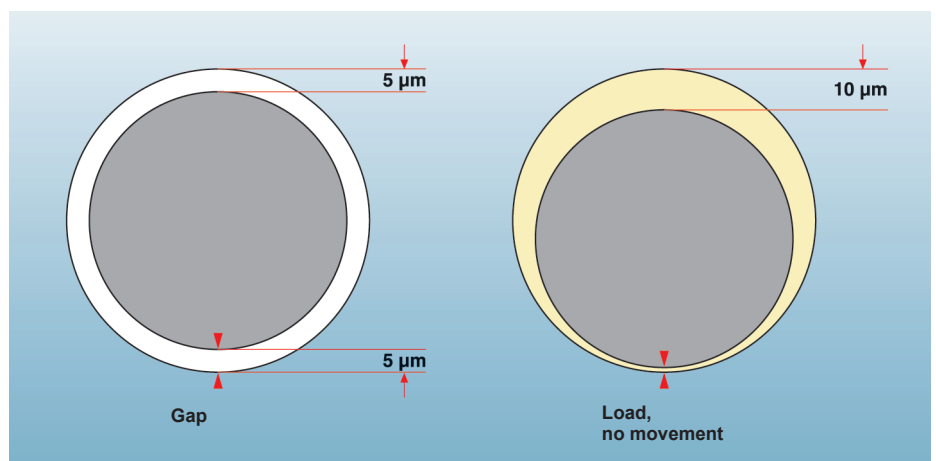

The operational or dynamic lubricating film is not the same as the machine clearance and is dependent on the force, speed and viscosity of the lubrication oil.

Therefore the lubricating film separates the moving surfaces in order to prevent metal-to-metal contact.

Components	Clearance ( $\mu\text{m}$ )
Plain bearing	0.5-100
Ball bearing	0.1-3
Hydrostatic ball bearing	1-25

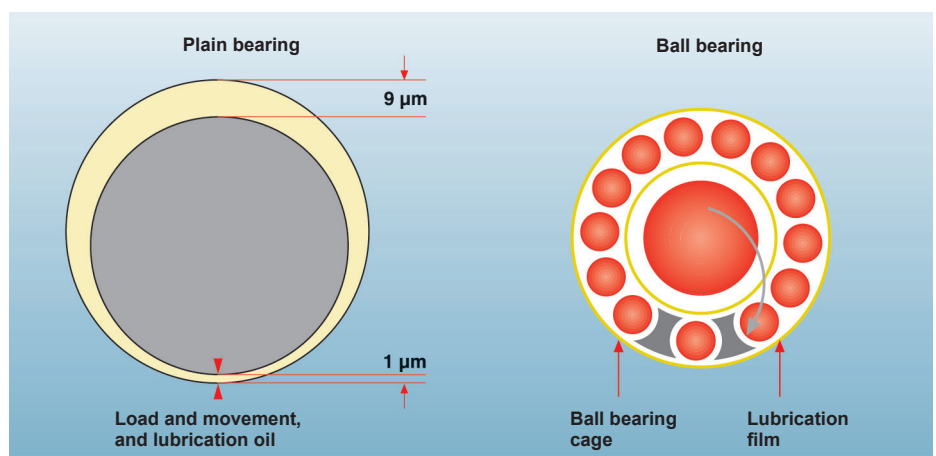

## What types of wear are there?

### 1. Abrasion

caused by particles between reciprocating surfaces.

### 2. Erosion

caused by particles and high fluid velocity.

### 3. Adhesion

caused by metal-to-metal friction (loss of fluid).

### 4. Surface fatigue

surfaces damaged by particles are subjected to repeated stress.

### 5. Corrosion

caused by water or chemicals (not examined below).

### Effects of wear in the case of a hydraulic cylinder:

Rod seal wear  
→ External oil leak

Guide bush wear  
→ Loss of rod alignment

Piston seal wear  
→ Loss of cylinder speed  
→ Loss of holding ability

Piston bearing wear  
→ Loss of rod alignment

### 1. Abrasion

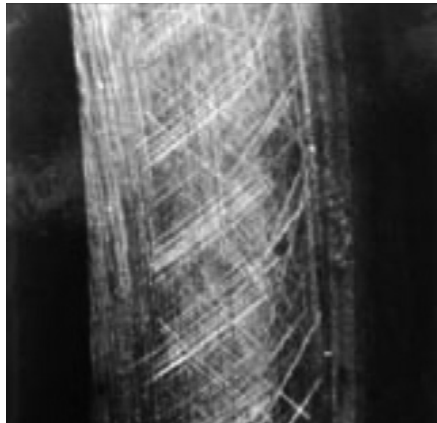
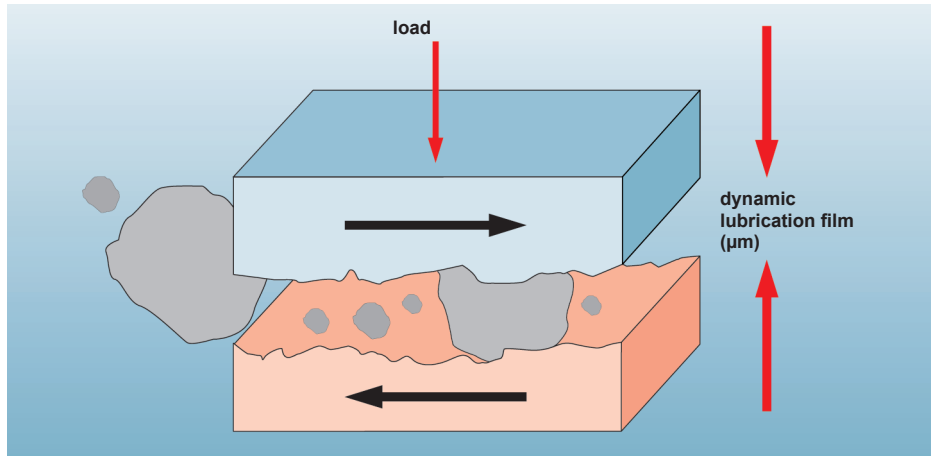

Abrasion caused by foreign bodies

### Effects of abrasion:

- Changes to tolerances
- Leakage
- Reduced efficiency
- Particles produced in the system create more wear!

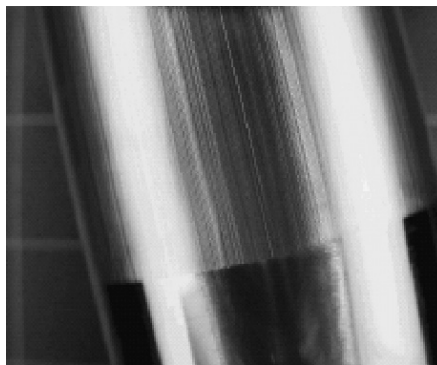
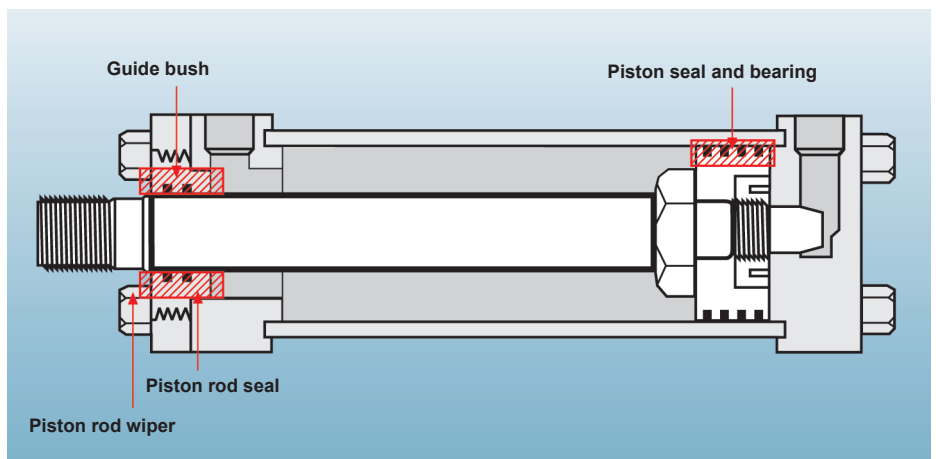

Damaged piston rod



### Effects of erosion:

The high velocity of the fluid forces existing particles against the corners and edges of the system. Other coarse and fine particles therefore become detached from the surface and there is a gradual attack on the surfaces in the system.

### 2. Erosion

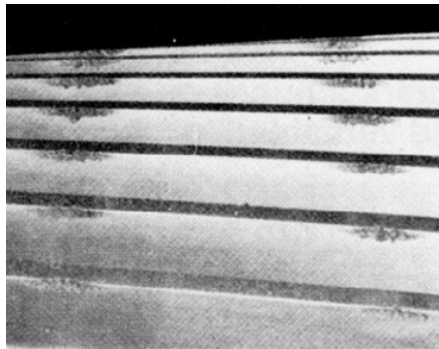
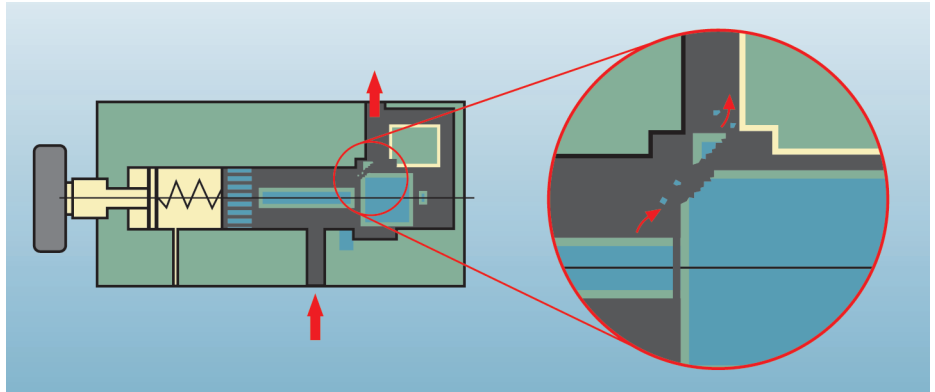

Erosion damage on the cog wheel

### Effects of adhesion:

Low speed, excessive load and/or a reduction in fluid viscosity can reduce the oil film thickness. This can result in metal-to-metal contact, and also possible shearing.

### 3. Adhesion

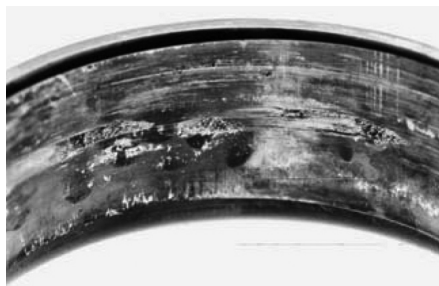
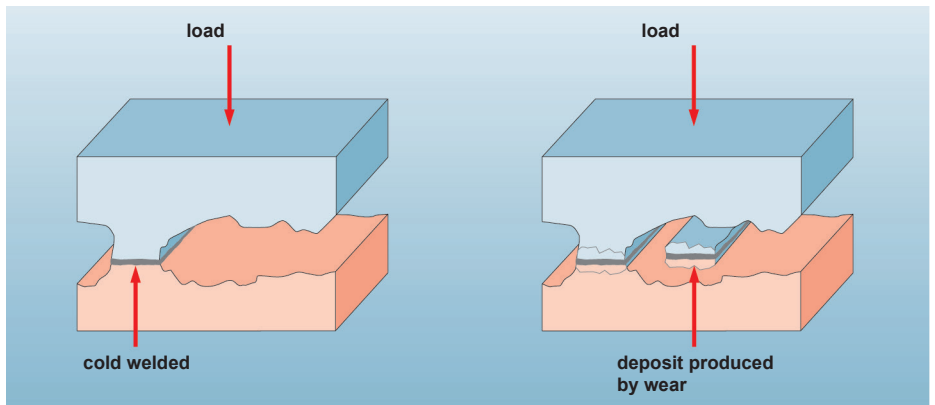

Adhesion on ball bearing

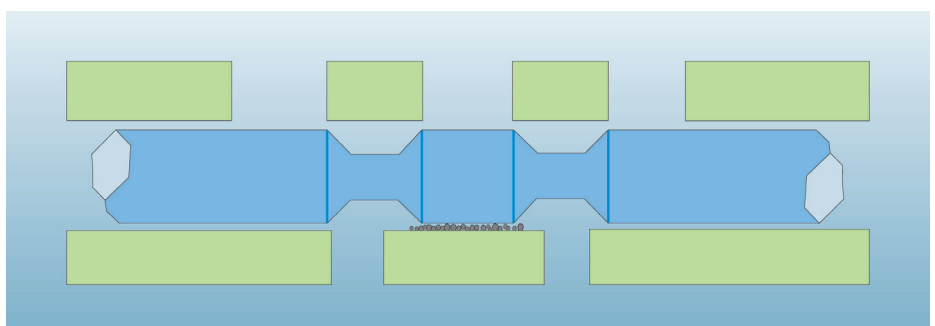

The smallest cracks in the surface are hollowed out causing material to break off, therefore creating new particles. This action causes an increase in wear.

#### 4. Surface fatigue

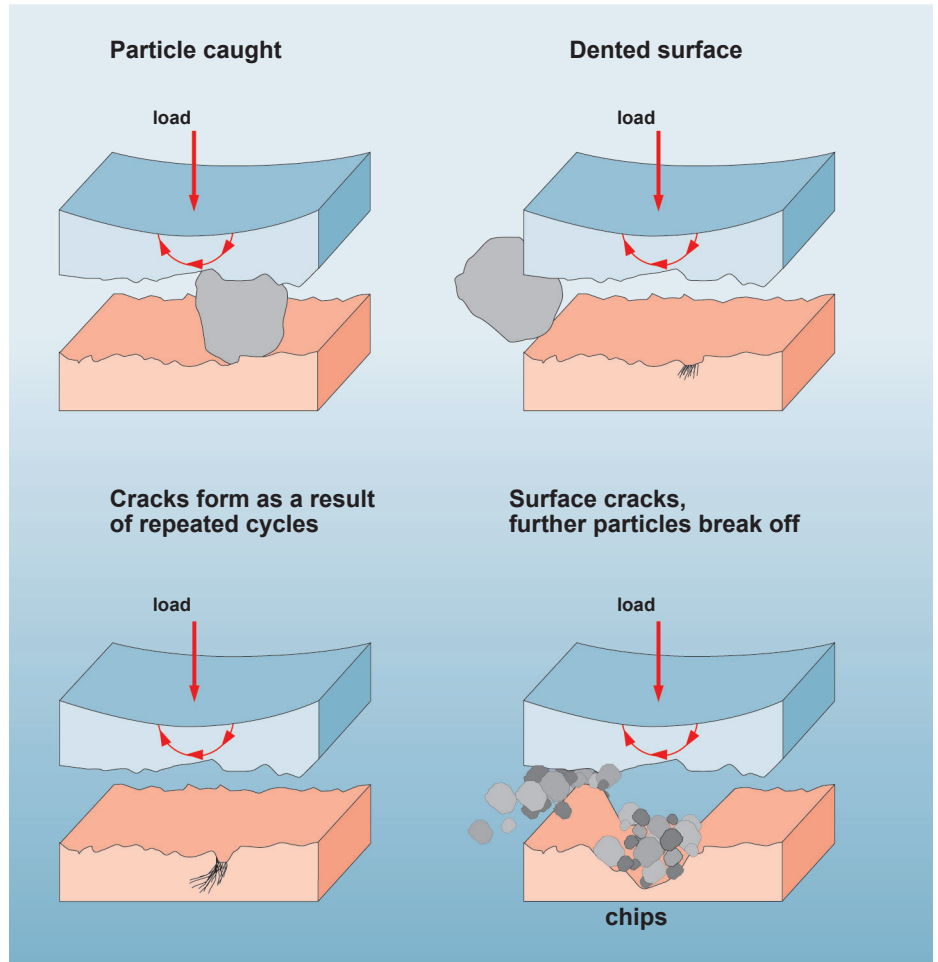

Surface fatigue on ball bearing



## How clean should the fluid be?

### Classification of the solid particle contamination

Solid particle contamination in lubrication and hydraulic fluid is classified according to ISO 4406/1999.

To determine the cleanliness level the solid particles present in 100 ml fluid are counted, sorted according to size & quantity and classified into particle ranges.

Depending on the method of particle counting, there are 2 or 3 ranges:

The ISO Code can be "translated" into a maximum particle quantity for each particle size range with the aid of the adjacent table.

This code is specified for each size range.

The oil cleanliness level determined by electronic particle counters is expressed as a combination of three numbers, e.g. 21/18/15; the particle quantity determined by microscopic counting is expressed as a combination of two numbers, e.g. -/18/15.

Particle counting method	Particle sizes (Code no.)		
	>4 $\mu\text{m}_{(C)}$	> 6 $\mu\text{m}_{(C)}$	> 14 $\mu\text{m}_{(C)}$
Automatic particle counter	>4 $\mu\text{m}_{(C)}$	> 6 $\mu\text{m}_{(C)}$	> 14 $\mu\text{m}_{(C)}$
Microscopic counting	---	> 5 $\mu\text{m}$	> 15 $\mu\text{m}$

ISO Code (to ISO 4406)	Particle quantity/100ml	
	from	to
5	16	32
6	32	64
7	64	130
8	130	250
9	250	500
10	500	1000
11	1000	2000
12	2000	4000
13	4000	8000
14	8000	16000
15	16000	32000
16	32000	64000
17	64000	130000
18	130000	260000
19	260000	500000
20	500000	1000000
21	1000000	2000000
22	2000000	4000000
23	4000000	8000000
24	8000000	16000000
25	16000000	32000000
26	32000000	64000000
27	64000000	130000000
28	130000000	250000000

### Determined using...

...electronic particle counter

21 / 18 / 15  
 >4 $\mu\text{m}_c$  >6 $\mu\text{m}_c$  14 $\mu\text{m}_c$

...microscopic counting

- / 18 / 15  
 >5 $\mu\text{m}_c$  15 $\mu\text{m}_c$

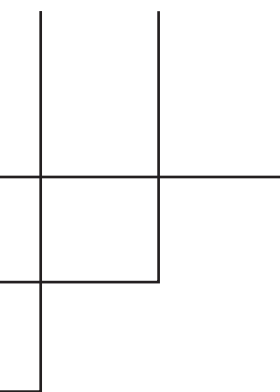

### Typical cleanliness level:

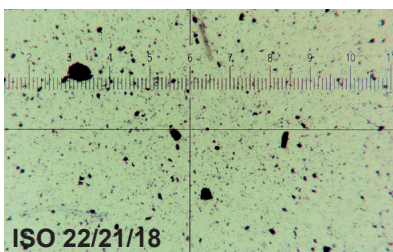

New oil, delivered in drums

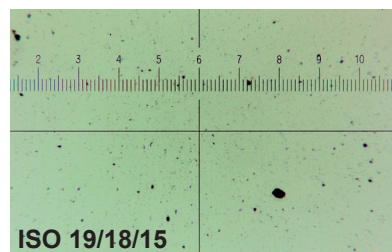

New oil, delivered in road tanker

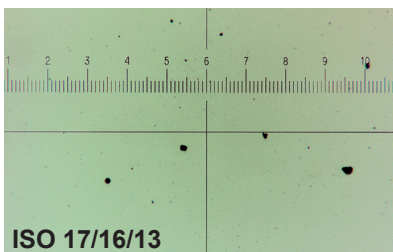

New oil, delivered in mini-container

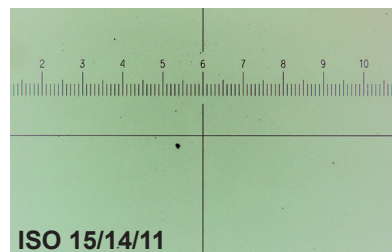

Required for modern hydraulic systems

## Cleanliness requirements for lubricating and hydraulic components

The cleanliness level required in lubricating and hydraulic systems is determined by the most sensitive component.

Numerous manufacturers of components for lubrication, industrial and mobile hydraulics specify the optimum cleanliness requirements for their components. If more heavily contaminated, the fluid can lead to a significant reduction in service life of those components. Therefore, we recommend contacting the particular manufacturer for written recommendations concerning the cleanliness of the fluid.

In the case of warranty claims, this information is important in order to reject claims for damages. If the component manufacturers do not have specific data concerning the required cleanliness level, the following table can be used:

The cleanliness levels shown in the table are based on an operating pressure from 100 to 160 bar, a normal level of ambient contamination and normal system availability.

Therefore, the following criteria must be taken into account when determining the required cleanliness class of the fluid:

Type of system/Area of application/Components	Recommended cleanliness class
Systems with servo hydraulics sensitive to fine contamination	15/13/10
Industrial hydraulics <ul style="list-style-type: none"> <li>● Proportional technology</li> <li>● High pressure systems</li> </ul>	17/15/12
Industrial and mobile hydraulics <ul style="list-style-type: none"> <li>● Solenoid control valve technology</li> <li>● Medium pressure and low pressure systems</li> </ul>	18/15/12 19/16/14
Industrial and mobile hydraulics with low requirement for wear protection	20/18/15
Forced-feed circulatory lubrication on transmissions	18/16/13
New oil	21/19/16
Pumps/motors <ul style="list-style-type: none"> <li>● Axial piston pump</li> <li>● Radial piston pump</li> <li>● Gear pump</li> <li>● Vane pump</li> </ul>	18/16/13 19/17/13 20/18/15 19/17/14
Valves <ul style="list-style-type: none"> <li>● Directional valves</li> <li>● Pressure valves</li> <li>● Flow control valves</li> <li>● Check valves</li> <li>● Proportional valves</li> <li>● Servo valves</li> </ul>	20/18/15 19/17/14 19/17/14 20/18/15 18/16/13 17/15/12
Cylinders	20/18/15

	Correction factor for the recommended cleanliness	
Operating pressure	less than 100 bar more than 160 bar	1 class worse 1 class better
Expected service life of the machine	up to 10 years over 10 years	no correction 1 class better
Repair and spare part costs	high	1 class better
Downtime costs due to shutdown	up to €10,000/hr. over €10,000/hr.	no correction 1 class better
Pilot system (system which significantly affects the manufacturing process or cycle)		1 class better

## What kinds of filters are there and when are they used?

### Installation location of a filter

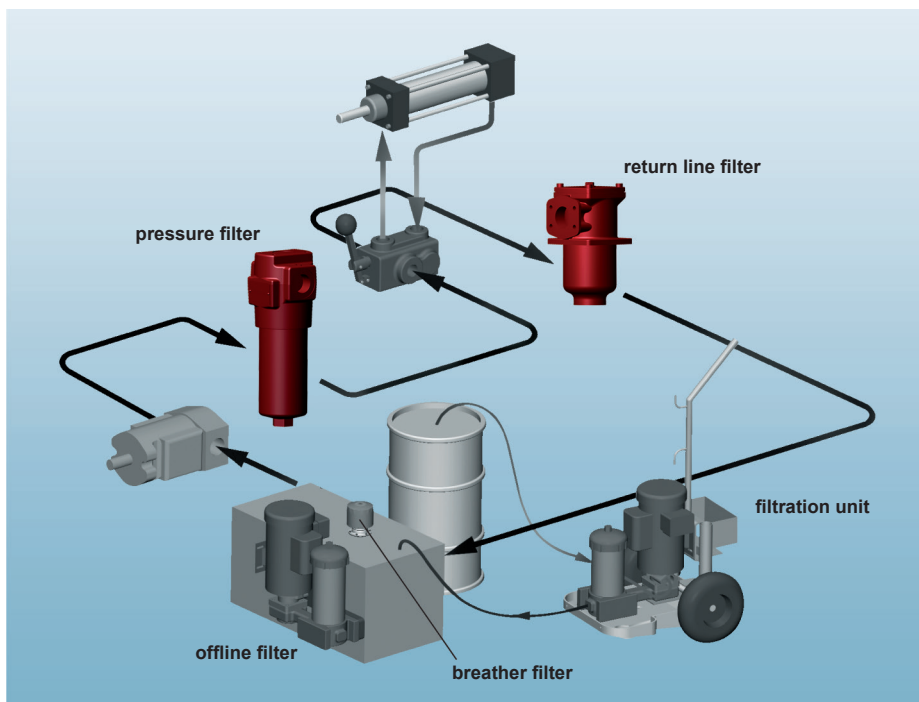

### Suction filters

These filters are installed between the tank and the booster pump to protect the pump from coarse contamination which can cause a high level of wear in the pump.

They can be installed inline, at the intake port in the tank or below the tank.

To prevent hazardous operating conditions for the pump, we recommend using a vacuum gauge between the filter and pump.

Due to the risk of pump cavitation, relatively coarse filter materials with a filtration rating of  $> 25 \mu\text{m}$  are used.

For this reason, suction filters are **not** suitable for ensuring the component protection necessary for the economical operation of the system.

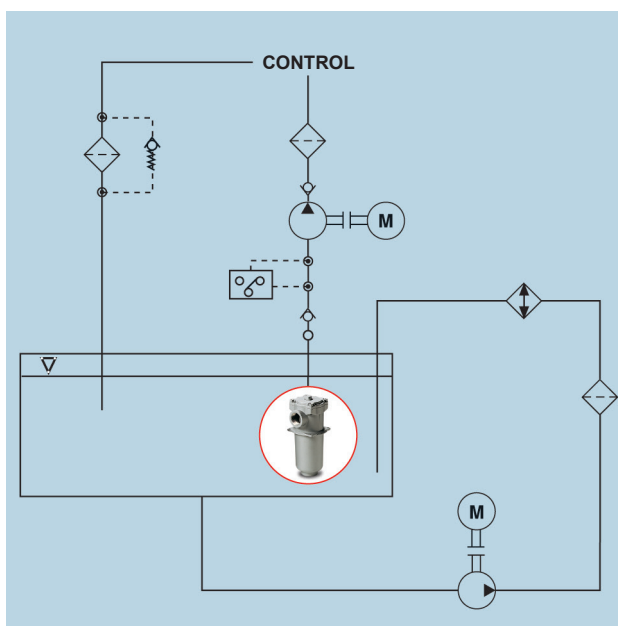

SF, SFM, suction filter element  
Extract from product range

Suction filters	
Advantages	Please note
<ul style="list-style-type: none"> <li>● Protects the pump against coarse contamination</li> </ul>	<ul style="list-style-type: none"> <li>● Fine filtration not possible</li> <li>● Pump must be protected against cavitation (vacuum switch)</li> <li>● Risk of cavitation, particularly at low temperatures (cold start)</li> <li>● To guarantee protection from wear, other filters must be installed</li> </ul>

## Pressure filters

This type of filter is defined in the DIN 24550 standard as an inline filter designed for a specific nominal pressure. It can be installed before or after the boost pump, but also in the return line between components and tank.

Wherever the filter is installed, the housing must be sized in accordance with the system pressure, the pressure pulsations and the flow rate.

To enhance the reliability of the whole hydraulic and lubrication system, filter housings are designed to have high fatigue strength. The filter housings are flow-optimized to be able to achieve a low pressure drop and a compact, space-saving design. They therefore make a significant contribution to the economy of the whole system. On mobile machines which comply with the latest regulations, the space-saving housing concept offers considerable advantages. To reduce the risk of unwanted leaks from the inline filter during operation, these can be integrated into a cost-optimized hydraulic or lubrication module. To protect particularly sensitive components, such as servo and proportional valves, we recommend installing this type of filter immediately before the component. However, in particular, the high dynamics in the control circuits must be taken into account in this case.

Inline filters which are fitted with filter elements where the flow is from out to in, should preferably be installed in systems which have high pressure pulsations and where the filter housing has no bypass valve.

On systems with a high contamination load, as with cooling lubricants, for which additional effective filtration of metallic particles is required, HYDAC recommends installing filter housings in which the flow through the filter elements is from in to out.

Depending on where the inline filter is installed in the machine, this type of housing offers advantages for element change.

Pressure filters must always be fitted with a clogging indicator. Before particularly critical components, only inline filters without bypass valves should be used. Such filters must be fitted with a filter element which must itself be able to withstand higher differential pressures, without sustaining any damage.

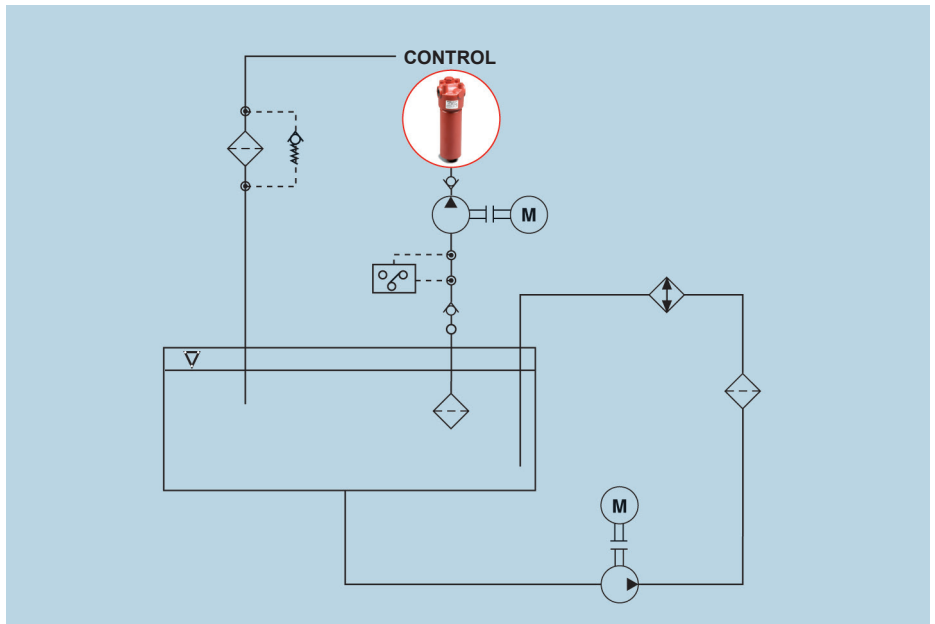

### Inline filter



DF 420 bar



MFM 280 bar



LPF 50 bar

Extract from product range

### Manifold-mounted filters



DFZ 315 bar



DF...M A 250 bar  
DF...Q E 315 bar



DFP 315 bar

Extract from product range

### Pressure filters

Advantages	Please note
<ul style="list-style-type: none"> <li>● Filtration is directly upstream of the components which need protection</li> <li>● Required cleanliness level is guaranteed</li> </ul>	<ul style="list-style-type: none"> <li>● More expensive filter housing and element due to pressure load</li> <li>● Complex element construction as a result of the necessary differential pressure resistance</li> <li>● Pump is not protected</li> <li>● In the case of single filters, the system has to be shut down to change the element.</li> </ul>

## Return line filters

This type of filter can either be installed inline (in the hydraulic tank line) or as a tank-mounted filter (on top of the hydraulic tank).

To prevent dangerous malfunctions in hydraulic components as a result of excessive back-pressure in the return line, return line filters are usually fitted with a bypass valve. For systems which are operated around the clock, the filter housing must be of the change-over type so that the system does not need to be shut down for filter maintenance. So that the oil flow is not interrupted during the change-over process, causing undersupply to the lubrication points, the change-over valve is designed with negative overlap.

When selecting the correct filter size, the maximum possible flow rate must be taken into account. This corresponds to the area ratio of piston to piston minus the rod of hydraulic cylinders and can be greater than the flow rate generated by the pumps.

In order to prevent possible foaming of the fluid in the tank, make absolutely sure that the fluid outlet from the filter is always below the fluid level in all operating conditions. It may be necessary to fit a pipe or flow rate diffuser in the filter outlet. It is important that the distance between the floor of the tank and the end of the pipe is no less than two to three times the pipe diameter.

Return line filters can be fitted with breather filters as additional equipment.

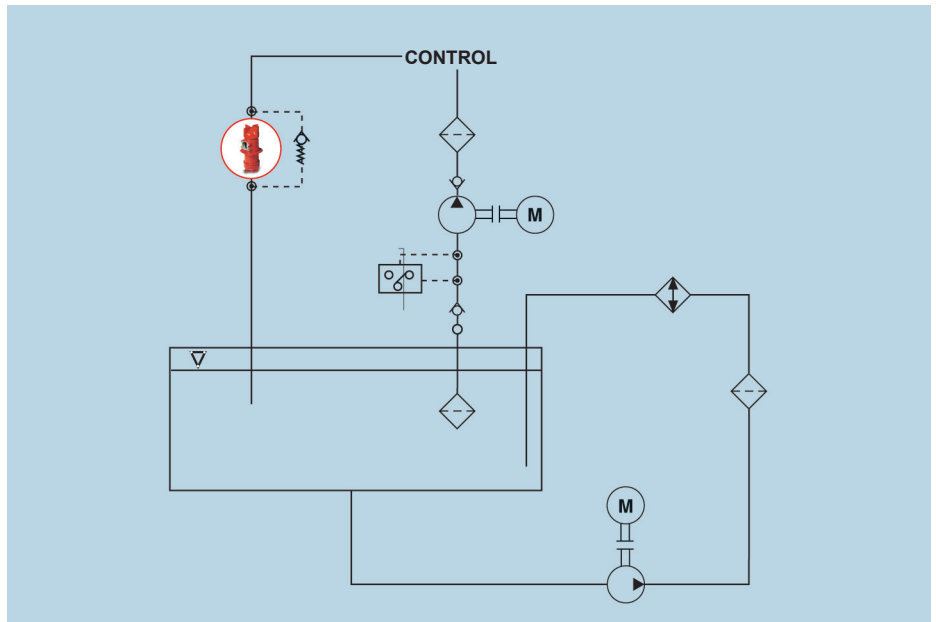

### Return line filters



RF



NF



RFN

Extract from product range

Return line filters	
Advantages	Please note
<ul style="list-style-type: none"> <li>● All fluid flowing back to tank is filtered</li> <li>● No system contamination reaches the tank</li> <li>● Filter housing and element are excellent value</li> </ul>	<ul style="list-style-type: none"> <li>● In the case of high-value components a pressure filter must be used in addition</li> <li>● It is advisable to fit a bypass valve</li> <li>● In the case of elements with low differential pressure resistance, it is possible for the element to burst as a result of multiple pulsations</li> <li>● In the case of single filters, the system has to be shut down to change the element</li> <li>● Large filters are required for high flow rates (area conversion for differential cylinders)</li> </ul>



## Return line & Suction Boost Filters

This type of filter has the advantage that the pump capacity (pressure and flow rate) installed in the steering and working hydraulics is implemented to supply the usually high-value drive hydraulics, which have a strict requirement for oil cleanliness, exclusively with filtered hydraulic oil.

In addition, dangerous operating conditions where negative pressure occurs on the suction side of the boost pump, is reduced to a minimum. Excellent cold start characteristics for the whole unit are the result.

To enhance the economy of the whole unit, this space-saving return line & suction boost filter, which is usually installed as a "return line filter" on the hydraulic tank, provides the means of reducing the oil circulation volume by installing a smaller tank.

In order to maintain the initial load of approx. 0.5 bar at the connection to the charge pump, a surplus of at least 10% between the return line volume and the suction volume is required under all operating conditions.

Through the use of a pressure relief valve, when the  $\Delta p$  reaches 2.5 bar, the oil flows directly into the tank (no bypass to the closed circuit).

If, in addition to the flow from the open circuit, the leakage oil from the hydrostatic drive also goes through the filter, then the permitted pressure of the leakage oil at the filter must not be exceeded (taking into account the pressure drop of the leakage oil lines, of the oil cooler and the pressure relief valve) to protect the radial shaft seal rings.

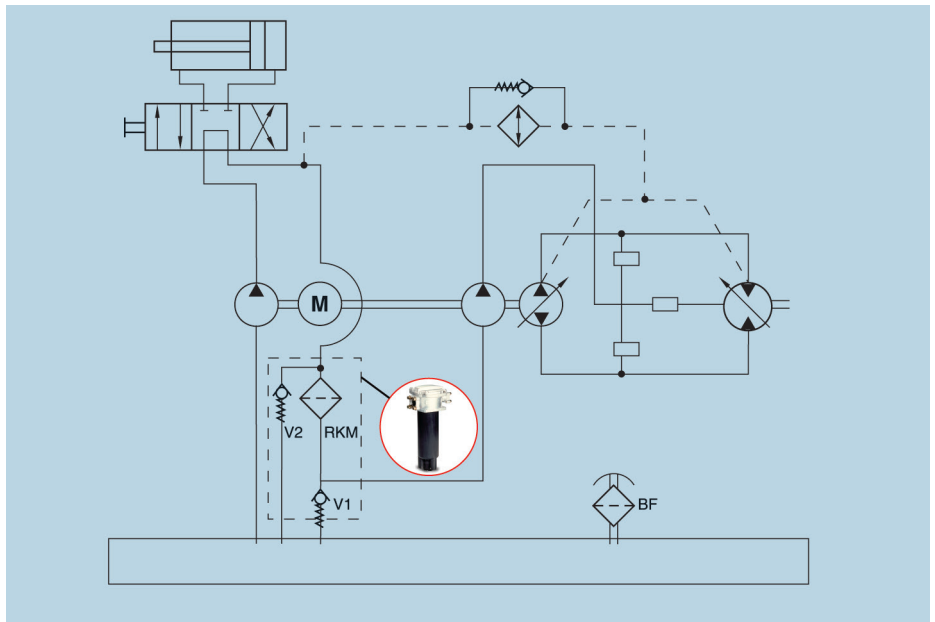

## Return line & Suction Boost Filters



RKM

### Return line & Suction Boost Filters

Advantages	Please note
<ul style="list-style-type: none"> <li>● Finely filtered oil supplied to consumer (increases the availability)</li> <li>● Oil is pre-charged in the suction connection (0.5 bar) (prevents cavitation, less wear)</li> <li>● Replaces several filters (lower fitting costs, only ONE spare element)</li> <li>● Extremely low pressure drop (full filtration at low temperatures)</li> <li>● Various options (thermal bypass valve, multi port)</li> </ul>	<ul style="list-style-type: none"> <li>● Useful if under operating conditions the return line volume is greater than the volume needed on the suction side</li> </ul>



## Offline filters

In hydraulic systems with heavy loads, additional offline filters are used increasingly to avoid the accumulation of fine particles.

In contrast to main filters, only part of the whole flow in the system is filtered by offline filters.

Excellent oil cleanliness levels can be achieved through continual filtration, regardless of the operating cycle of the machine. In addition, the main filters are relieved, meaning that element changing intervals can be extended.

Offline filter systems should be used in addition to main filters. In this case the main filter should be sized as a protective filter, i.e. filtering less finely and without a bypass valve.

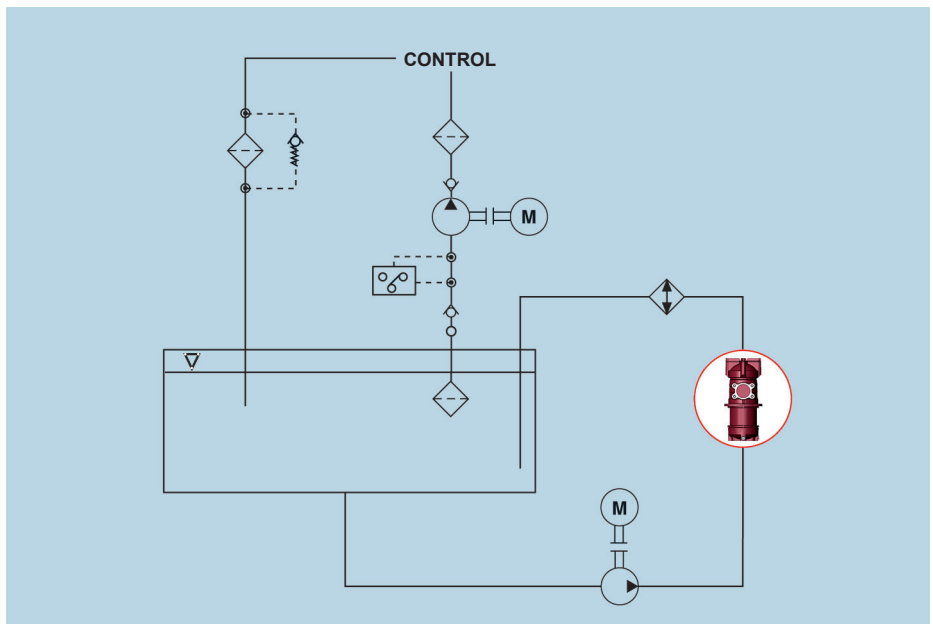

## Offline filters



Extract from product range

NF

### Offline filters

#### Advantages

- Excellent cleanliness classes
- Filtration independent of the system
- High contamination retention capacity of filter elements as a result of pulsation-free, low and constant flow through the filter elements
- Element change possible without stopping the machine
- Cost savings as a result of lower material costs
- Less time spent on maintenance
- Fewer downtimes
- Cost-effective filter elements
- Possible to fill hydraulic system
- Can be easily retrofitted in systems with insufficient filtration
- Dewatering of the fluid is possible
- Service life of fluid in the system is extended

Generally speaking, offline filters should be installed:

- if a high rate of contamination is expected, e. g. on production test rigs, large-scale systems in dusty areas, cleaning systems
- when installing a separate cooling circuit
- when there are vigorous changes in system flow rate

## Tank breather filters

Tank breather filters are one of the most important, yet neglected, components in filter design.

As a result of changes in temperature and of using cylinders or accumulators, the oil level in the tanks of hydraulic and lubrication systems is subject to constant fluctuations.

The resulting pressure differential to the ambient is equalized by an exchange of air which means contamination can get into the tanks.

Breather filters can prevent contamination from entering. Ideally the breathers should be of at least the same filtration rating as the system filter in the hydraulic circuit. By using breather filters with double check valves, the air exchange between the tank and the ambient can be significantly reduced, minimizing the amount of contamination and dust entering the tank and increasing the service life of the breather filter.

Where there are high temperature changes and high humidity, water also enters the tank. HYDAC BD filters prevent water from entering and therefore improve the fluid performance.

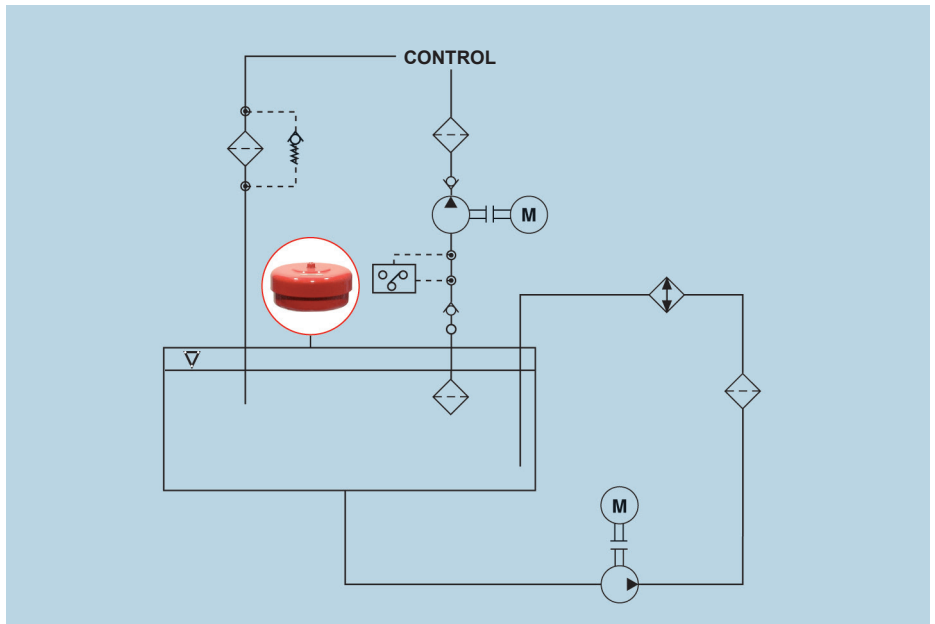

### Tank breather filters



BF



ELF/L



BDE

Extract from product range

Breather filters	
Advantages	Please note
<ul style="list-style-type: none"> <li>● Relieves the system filter by preventing contamination from entering the tank during tank breathing</li> <li>● High air flow rate</li> <li>● Cost-effective</li> <li>● Environmentally-friendly</li> </ul>	<ul style="list-style-type: none"> <li>● If the filter is incorrectly sized, damage may occur to the tank and the pump.</li> </ul>

## Summary

Filter location	Advantages	Please note	Filter designation
Breather filters	<ul style="list-style-type: none"> <li>● Relieves the system filter by preventing contamination from entering the tank during tank breathing</li> <li>● High air flow rate</li> <li>● Cost-effective</li> <li>● Environmentally-friendly</li> </ul>	<ul style="list-style-type: none"> <li>● If the filter is incorrectly sized, damage may occur to the tank and the pump.</li> </ul>	BDL, BDE, BDM, BF, BL, BLT, ELF, ELFL
In the suction line	<ul style="list-style-type: none"> <li>● Pump protection</li> </ul>	<ul style="list-style-type: none"> <li>● Coarse filtration only</li> <li>● Due to the pump suction conditions, generously sized filters with a low differential pressure are required</li> <li>● No protection of components further downstream from pump wear</li> <li>● Unsuitable for many control pumps</li> <li>● Minimum system protection</li> <li>● It is essential to protect the pump against vacuum pressure</li> </ul>	LF, LPF, MF, MFD, RFL, RFLN, SF, SFE, SFF, SFM, SFAR
In the pressure line	<ul style="list-style-type: none"> <li>● Direct protection of the components</li> <li>● Contributes to the general cleanliness of the system</li> <li>● Highly efficient fine filter elements can be used</li> <li>● Filters pump drive systems</li> </ul>	<ul style="list-style-type: none"> <li>● Housing and element expensive since they must be sized for the max. system pressure</li> <li>● Does not filter contamination from components further downstream</li> <li>● High energy costs</li> </ul>	DF, DF...M A, DF...Q E, DF...MHA, DF...MHE, DFDK, DFF, DFG, DFM, DFN, DFNF, DFP, DFZ, HDF, HDFF, HFM, ILF, ILFR, LF, LFDK, LFF, LFM, LFN, LFNF, LFR, LPF, LPF...D A, LPFR, MDF, MDFR, MF, MFD, MFX
In the return line	<ul style="list-style-type: none"> <li>● Filters the contamination which has entered the system as a result of component wear and worn wipers before it can reach the hydraulic tank</li> <li>● Low pressure sizing of the filter housing enables costs to be reduced</li> <li>● Can be installed inline or in the tank</li> </ul>	<ul style="list-style-type: none"> <li>● No protection of the pump</li> <li>● Return line flow rate fluctuations can reduce the filtration efficiency</li> <li>● No direct component protection</li> <li>● Large filters may be required, since the return flow is often larger than the pump flow</li> </ul>	AFLD, AFLS RF, RFM, RKM, RFL, RFLD, RFN, RFD, RFND, RFLN, RFLR, RKMR, RMER, RMTR, RPER
Offline e.g. cooling circuit	<ul style="list-style-type: none"> <li>● Continuous cleaning of the hydraulic fluid, also when system is shut down</li> <li>● Maintenance can be carried out when system is running</li> <li>● Filtering action is not impaired by fluctuations in flow and provides optimum service life and efficiency of filter elements</li> <li>● Possible to fill the tank with filtered new oil</li> <li>● Particular cleanliness level can be achieved and maintained accurately.</li> <li>● Possible to install fluid cooling easily</li> </ul>	<ul style="list-style-type: none"> <li>● High investment costs</li> <li>● Additional space-requirement</li> <li>● No direct component protection</li> </ul>	NF, NFD, LF, MF

## Filter selection

Filter efficiency is the most important but not the only factor involved when evaluating the filter design. A filter can be ineffective if it is installed in the wrong place and if it is given the wrong job.

When creating a filtration concept, some **fundamental rules** play a crucial role.

For example, the function of a hydraulic filter is always to reduce wear which means it should filter to a finer level than the critical tolerances. Filters should be used with the highest possible flow rate. Suitable seals on cylinders and on breather filters should prevent contamination from entering the system etc.

Therefore we can distinguish between **protective filters** and **working filters**.

## Restricting the flow velocity

Since specific flow velocities in the connection lines must not be exceeded, depending on the filter type, we recommend only special maximum flow rates.

Here we give guideline values which are based on our experience. Exceptions, depending on the application, are of course possible and reasonable.

## Determining the appropriate filter element

Depending on the conditions of the system and the environment, filters with the same filtration rating perform differently.

The following cleanliness classes are typical for HYDAC elements:

Protective filter	Working filter
● Component protection	● Cleaning function
● No bypass valve	● Flow with least possible pulsations where filter installed
● Does not prevent long-term wear	● Bypass valve available as an option
● Filters more coarsely than working filter	● Differential pressure indicator is recommended
● High differential pressure resistant filter elements	● Use of low differential pressure resistant elements is possible









Threaded connection	Maximum recommended flow rate in l/min				
	Suction filter 1.5 m/s	Return line filter 4.5 m/s	Pressure filter up to 100 bar 4.5 m/s	Pressure filter up to 280 bar 8 m/s	Pressure filter up to 420 bar 12 m/s
G 1/2	14	42	42	46	68
G 3/4	23	69	69	74	111
G 1	37	112	112	119	178
G 1 1/4	59	178	178	182	274
G 1 1/2	92	275	275	295	443
DN50	175	525	725	950	1425
DN65	296	887	1225	1606	2408
DN80	448	1344	1856	2432	3648
DN100	700	2100	2900	3800	5700
DN125	1094	3281	4531	5937	8906
DN150	1575	4725	6525	8550	12825
DN200	2800	8400	11600	15200	22800
DN250	4375	13125	18125	23750	35625

Filtration rating x ( $\beta_{x(e)} \geq 200$ )	25	19/16/13 - 22/19/16											
	20	18/15/12 - 21/18/15											
	15	17/14/11 - 20/17/14											
	10	15/12/9 - 19/16/13											
	5	12/9/6 - 17/14/11											
	3	10/7/4 - 13/10/7											
		10/7/4	11/8/5	12/9/6	13/10/7	14/11/8	15/12/9	16/13/10	17/14/11	18/15/12	19/16/13	20/17/14	21/18/15

### Oil cleanliness to ISO 4406

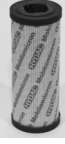
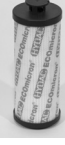
## Selection of the appropriate filter material

The variety of applications of HYDAC filters has given rise to different element models, each specifically optimized for particular requirements. We are therefore in a position to provide you with the type of element most technically and economically appropriate for your special application. The following table outlines the most important filtration media. Our sales team is always available to help you select the filtration media which is most appropriate for your application.

	Element designation	Construction of filter mesh pack	Typical features
Synthetic fine filtration materials			
	Optimicon® ON (20 bar)	Multiple-layer, supported, pleated (Helios pleat geometry) filter mesh pack with glass fibre	<ul style="list-style-type: none"> <li>● Low rise in differential pressure</li> <li>● New "Helios" pleat geometry to stabilise the pleats and increase available area of incident flow</li> <li>● First class filtration efficiency</li> <li>● Outer wrap with improved diffuser effect</li> </ul>
	Optimicon® Power ON/PO (10 bar)	Multi-layer, supported, pleated filter mesh pack with glass fibre	<ul style="list-style-type: none"> <li>● Low pressure drop</li> <li>● Filtration performance defined according to API specifications</li> <li>● Homogeneous flow of the fluid</li> <li>● Stat-Free® technology inclusive</li> </ul>
	Optimicon® Pulse ON/PS (20 bar) OH/PS (210 bar)	Single-layer, supported, pleated (Helios pleat geometry) filter mesh pack with glass fibre	<ul style="list-style-type: none"> <li>● Particularly high fatigue strength</li> <li>● Low rise in differential pressure</li> <li>● Integrated Stat-Free® technology</li> </ul>
	Optimicon® Pulp & Paper ON/PP (10 bar)	Multiple-layer, supported, pleated (Helios pleat geometry) filter mesh pack with glass fibre	<ul style="list-style-type: none"> <li>● Differential pressure greatly reduced</li> <li>● Significantly increased contamination retention capacity</li> <li>● Exclusive micro-glass media</li> <li>● Outer wrap with improved diffuser effect</li> </ul>
	Betamicron® BN4HC (20 bar) BH4HC (210 bar)	Multi-layer, supported, pleated filter mesh pack with glass fibre	<ul style="list-style-type: none"> <li>● High contamination retention</li> <li>● High rate of particle separation over a wide differential pressure range</li> <li>● High resistance to pressure and flow rate fluctuations</li> </ul>
	Mobilemicon MM	Multi-layer, supported, pleated filter mesh pack with synthetic fibre	<ul style="list-style-type: none"> <li>● High rate of particle separation</li> <li>● Low pressure drop</li> <li>● Sufficient contamination retention</li> <li>● First class filtration in the suction range possible</li> </ul>
	Ecomicon ECON2	Multi-layer, supported, pleated filter mesh pack with glass fibre, support tube and end caps in electrically conductive synthetic material	<ul style="list-style-type: none"> <li>● High rate of particle separation</li> <li>● Low pressure drop</li> <li>● High contamination retention</li> <li>● Uses first class synthetic materials which can easily be disposed of</li> <li>● Low weight</li> <li>● Free of steel and iron</li> </ul>
Paper			
	Paper P/HC	Simply supported, pleated, organic paper (usually impregnated with phenolic resin)	<ul style="list-style-type: none"> <li>● Cheap element</li> <li>● Low level of particle removal and contamination retention (Multipass usually not possible)</li> <li>● Low pressure drop</li> <li>● Low pressure stability (bypass absolutely necessary)</li> </ul>
Stainless steel and wire mesh materials			
	Wire mesh or dutch weave W/HC or T/HC	Multi-layer or single-layer, supported, pleated square mesh in stainless steel or dutch weave	<ul style="list-style-type: none"> <li>● Protective filter with low filtration performance and contamination retention</li> </ul>
	Chemicon and Metal fibre V	Multi-layer, pleated mesh pack with sintered stainless steel fibre	<ul style="list-style-type: none"> <li>● All the components used in the element are in stainless steel.</li> <li>● On the element type "metal fibre V" the components are bonded using a 2-component adhesive (max. temperature 100 °C).</li> <li>● On the "Chemicon" element the element components are bonded without the use of adhesive.</li> </ul>

## Filter sizing

Once the element material, the required filtration rating and the filter construction have been established, the size of the filter can be determined. Here we can assume that the initial pressure drop of a filter does not exceed a specific value, or that it comes as close as possible to this value (see adjacent table).

The total pressure drop of a filter (at a specific flow rate Q) is the sum of the housing  $\Delta p$  and the element  $\Delta p$  and is calculated as follows:

### Example

Sizing a return line filter, tank mounted, type RFM 150, element material Betamicon®4, 10 µm filtration rating, Flow rate in the return line: 60 l/min, operating fluid: ISO VG 46, operating temperature: 40 °C.

Note:  
At 40 °C this oil has an operating viscosity of approx. 46 mm<sup>2</sup>/s (always take manufacturer's data into account).

Use as	Filter type	Total initial differential pressure (with new filter element)
Working filter	Return line filter, Pressure filter with bypass valve	0.15 to 0.2 • Pressure setting of clogging indicator (P <sub>indicator</sub> )
	Offline filter, Inline filter, Separate units	0.15 to 0.2 bar
Protective filter	Pressure filters without bypass valve	0.3 • P <sub>display</sub>
	Suction filter	0.04 bar

$$\Delta p_{\text{total}} = \Delta p_{\text{housing}} + \Delta p_{\text{element}}$$

$$\Delta p_{\text{housing}} = \text{please refer to housing curve (see brochure)}$$

$$\Delta p_{\text{element}} = Q \cdot \frac{\text{element gradient coefficient}}{1000} \cdot \frac{\text{operating viscosity}}{30}$$

**Max. initial differential pressure: 1 bar (=0.2 • P<sub>indicator</sub> = 0.2 • 2 bar = 0.4 bar)**

$\Delta p_{\text{housing}}$ :  
(please refer to "RFM" brochure)

**RFM 90, 150**

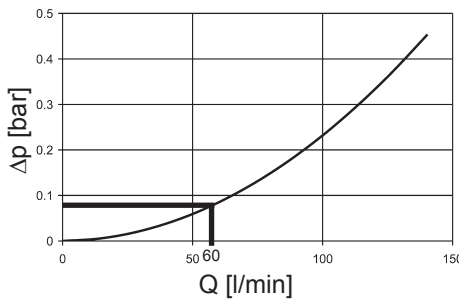

$\Delta p_{\text{element}}$ :  
(for gradient coefficients for element 0150 R 010 BN4HC please refer to "Filter Elements" brochure or "RFM" brochure)

$$60 \text{ l/min} \cdot \frac{4.0}{1000} \cdot \frac{46 \text{ mm}^2/\text{s}}{30} = 0.368$$

$$\Delta p_{\text{total}} = \Delta p_{\text{housing}} + \Delta p_{\text{element}} = 0.09 + 0.368 = 0.458 \text{ bar}$$



## What is the procedure in practice?

If you calculate on the generous side, i.e. choosing the larger filter, this will provide a longer service life, and will probably cost more. But if the sizing is only just adequate, i.e. you select the smallest possible filter, you risk a shorter service life and reduced component protection despite lower purchase costs.

The aim, of course, is to find the most economical filter whilst taking into consideration the total system life cycle (reduction of the Life Cycle Cost).

## Computer-aided filter sizing using Filter Sizing Program "Size-IT".

**Size-IT** enables computer-aided filter sizing, specific to the particular system and application profile.

Size-IT is a component of our electronic product catalogue, **Filter-IT**.

We will, of course, be pleased to send you a copy. Alternatively the program is available on our website ([www.hydac.com](http://www.hydac.com)).

**Size-IT** automatically computes all calculations, which in the previous example, had to be carried out painstakingly step by step.

Possible errors when reading graph data are avoided; the time saving is considerable.

The size of the filter can be determined with the help of

- Housing and element pressure drop curves in the brochures (= manual filter sizing)
- Filter sizing program **Size-IT** (= computer-aided filter sizing)
- Concept creation tool **Optimize-IT** (= computer-aided system optimization)

## Example of a filter calculation using sizing software "Size-IT".

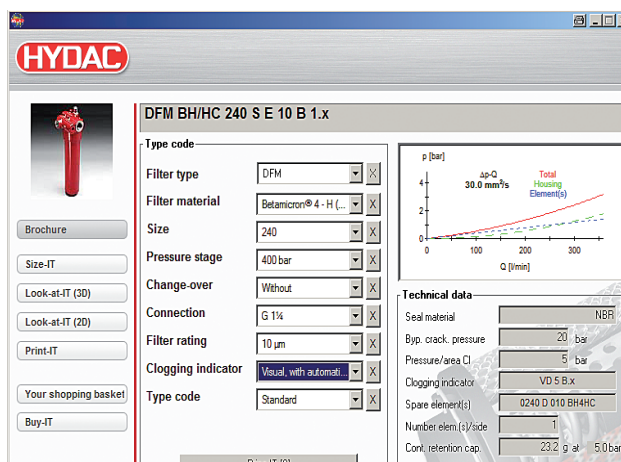

**Filter calculation according to the expected contamination rate using the concept creation tool "Optimize-IT"**

This electronic tool, called **"Optimize-IT"**, is also a component of our electronic product catalogue, but is only available to our filter specialists. Cleanliness classes and achievable service lives for different filter designs can be identified and compared using this tool.

Based on the expected contamination, the optimum filter combination and filter size combination can be determined, right down to a specific calculation of the element costs per year.

**Example of concept optimization using the electronic tool "Optimize-IT":**

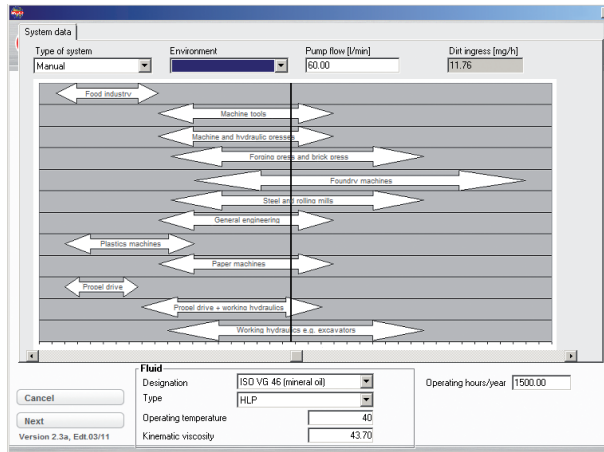

Determining the expected contamination for a particular system

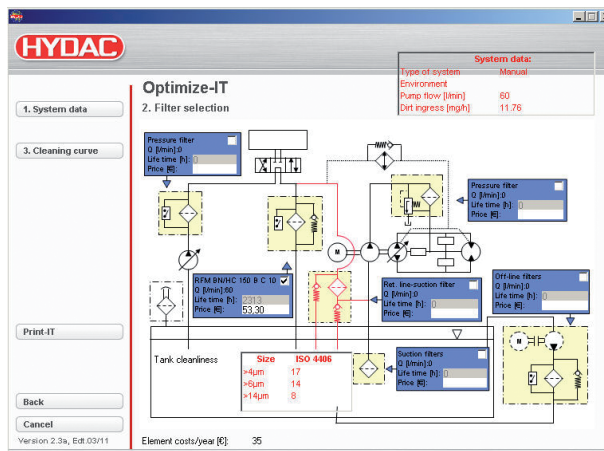

Calculation of the service lives and element costs/year

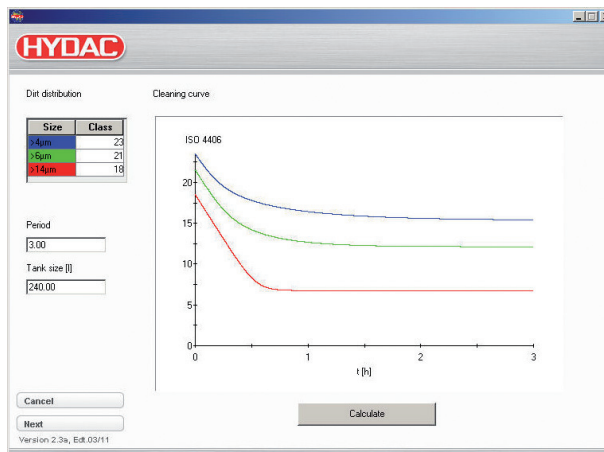

Graph showing cleaning